

TRANSLATION

January 27, 2015

Real Estate Investment Trust Securities Issuer
Sekisui House SI Residential Investment Corporation
3-1-31 Minami-Aoyama, Minato-ku, Tokyo
Representative: Osamu Minami, Executive Director
(Securities Code: 8973)

Asset Management Company
Sekisui House SI Asset Management, Ltd.
3-1-31 Minami-Aoyama, Minato-ku, Tokyo
Representative: Osamu Minami, President
Inquiries: Yoshiya Sasaki, General Manager
IR & Financial Affairs Department
TEL: +81-3-5770-8973 (main)

Notice Concerning Acquisition of DBJ Green Building Certification for Residential Properties
for the First Time among J-REITs

Sekisui House SI Residential Investment Corporation (the “Investment Corporation”) hereby announces that it today received DBJ Green Building Certification for two of its owned properties (Prime Maison SHINAGAWA and Prime Maison GOTENYAMA EAST) from Development Bank of Japan (“DBJ”) in recognition of their exceptionally high “environmental and social awareness”, as described below. This is the first case of the Certification granted to residential properties.



For details of the announcement by DBJ, please refer to the following website.

DBJ website: http://www.dbj.jp/ja/topics/dbj_news/2014/html/0000018403.html (Japanese)

1. Overview of DBJ Green Building Certification

The DBJ Green Building Certification System (the “System”) is designed to mark buildings by using a scoring model originally developed by DBJ and select blue-chip real estate that meets the demands of the times. Its purpose is to promote real properties that demonstrate environmental performance as well as security measures and disaster prevention measures and take into account the social requirements from various stakeholders surrounding the properties (“Green Buildings”).

2. Rank and Assessment Points of Properties Certified by the System

Certified Property	Prime Maison SHINAGAWA	Prime Maison GOTENYAMA EAST
Certification Rank	 <p>Properties with exceptionally high environmental & social awareness</p>	 <p>Properties with exceptionally high environmental & social awareness</p>
Assessment Points	<p>(1) Proactively promotes energy saving and energy creation by employing LED lighting for not only common areas but also exclusive areas, as well as installing photovoltaic power generation panels, to demonstrate how sustainable residences should be</p> <p>(2) Conducts greening on the rooftop and walls, and gives considerations to biodiversity by frequently planting Japan’s original, wild and native species that have long been familiar to the local community, based on the “Gohon no ki” (Five Trees) project promoted by Sekisui House, Ltd., the developer</p> <p>(3) (Particularly for Prime Maison SHINAGAWA) Responds to a variety of tenant needs by introducing latest facilities, including installment of electric vehicle battery chargers as well as emergency power sources that are directly connected to the photovoltaic power generation panels to supply electricity to the common areas</p>	

This translation is for informational purposes only. If there is any discrepancy between the Japanese version and the English translation, the Japanese version shall prevail.

積水ハウス・SI レジデンシャル投資法人

Sekisui House SI Residential Investment Corporation

3. Overview of Properties Certified by the System

Certified property	 Prime Maison SHINAGAWA	 Prime Maison GOTENYAMA EAST
Appearance		
Address	1-3-16 Kita-Shinagawa, Shinagawa-ku, Tokyo	6-6-33 Kita-Shinagawa, Shinagawa-ku, Tokyo
Structure	RC	RC
Number of Floors	6F	4F/B1
Site area	972.94m ²	2,167.60m ²
Total floor area	2,693.31m ²	3,727.89m ²
Completion Date	February 18, 2014	January 18, 2011
Acquisition Date	November 4, 2014	October 1, 2013

4. Future Efforts by the Investment Corporation

The Investment Corporation will promote initiatives for energy saving and environmental awareness in response to the requirements of the times through such measures as enhancing energy efficiency of its owned properties and acquiring environmentally friendly properties. To do so, the Investment Corporation will cooperate with Sekisui House, Ltd., the main sponsor, which has been recognized as Eco-First Company by the Ministry of the Environment for the first time in the housing industry.

*The Eco-First Company refers to a company that made a pledge to the Minister of the Environment about its commitment to environmental preservation, including countermeasures against global warming and waste reduction and recycling measures, and has been recognized by the Minister that it is engaged in “advanced, original and industry-leading business activities” in the environment areas.

As of today, 40 companies have been certified as Eco-First Company.

For more details, please refer to the website of the Ministry of the Environment at:

<http://www.env.go.jp/guide/info/eco-first> (Japanese)

* Sekisui House SI Residential Investment Corporation website: <http://www.shsi-reit.co.jp/eng/>

積水ハウス・SI レジデンシャル投資法人
 Sekisui House SI Residential Investment Corporation

<Reference 1>

□ **“Gohon no ki” (Five Trees) project Promoted by Sekisui House, Ltd.**

The “Gohon no ki” (Five Trees) project is a proposal for creating gardens to facilitate communications with nature, promoted by Sekisui House, Ltd, the main sponsor of the Investment Corporation. It is an initiative to plant Japan’s original, wild and native species that have long been familiar to the people in accordance with the local weather, with a prayer of “three trees for birds and two trees for butterflies”. The initiative focuses on biodiversity, giving considerations to the links of creatures residing in plants.

□ **[Prime Maison SHINAGAWA] Schematic Diagram of Greening Plan**

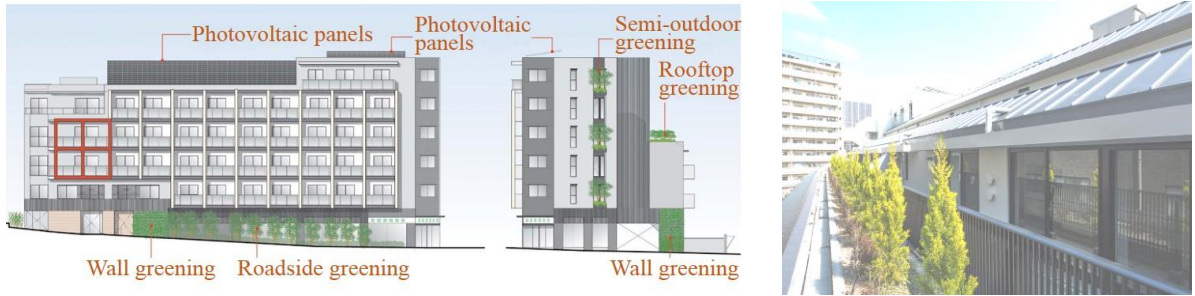

□ **[Prime Maison SHINAGAWA] Conceptual Diagram of Emergency Power Supply System**

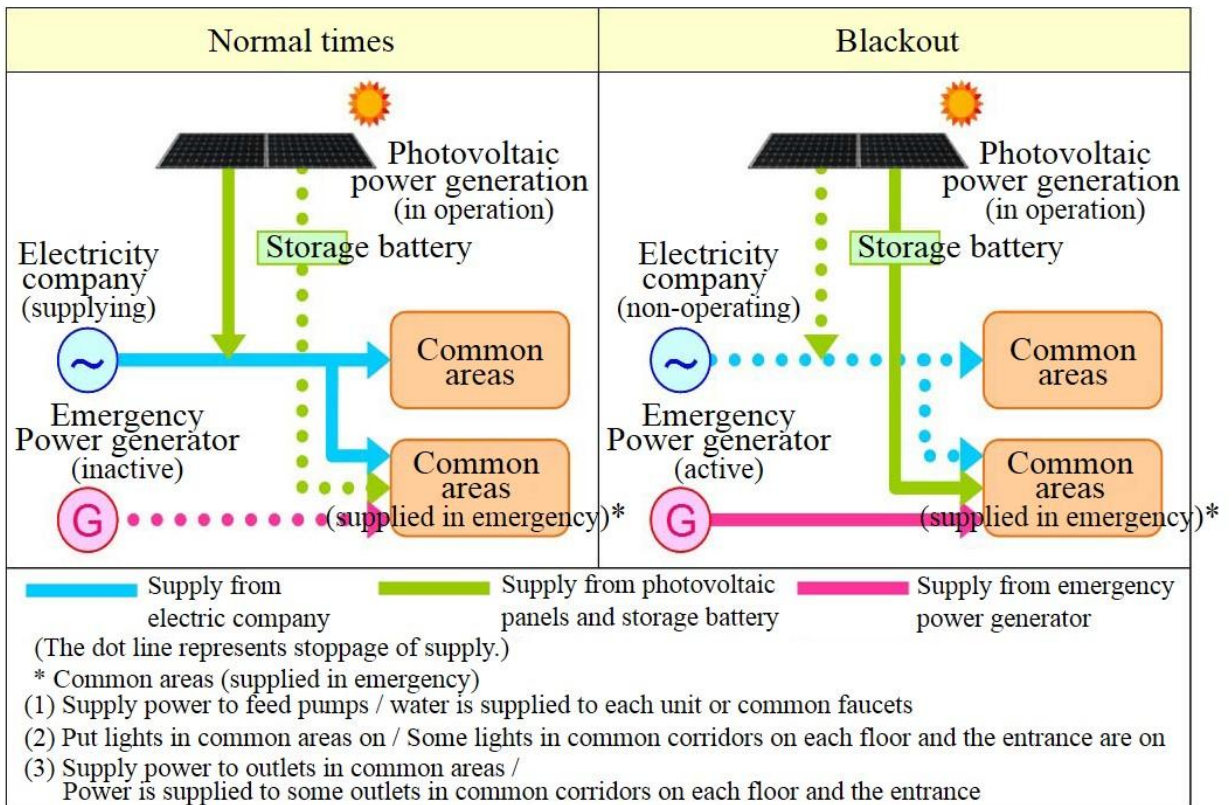

This translation is for informational purposes only. If there is any discrepancy between the Japanese version and the English translation, the Japanese version shall prevail.

積水ハウス・SI レジデンシャル投資法人
 Sekisui House SI Residential Investment Corporation

[Prime Maison GOTENYAMA EAST] Rooftop photovoltaic panels and rooftop greening



<Reference 2>

Assessment Ranks of the DBJ Green Building Certification

The System marks buildings by using a scoring model originally developed by DBJ. The following five ranks of certification are granted in accordance with the scoring results.

No certification may be granted, depending on the scoring results.

Properties with the best class environmental & social awareness	Properties with exceptionally high environmental & social awareness	Properties with excellent environmental & social awareness	Properties with high environmental & social awareness	Properties with satisfactory environmental & social awareness
5 Stars	4 Stars	3 Stars	2 Stars	1 Stars
				

For details of the DBJ Green Building Certification System, please refer to the following:

Website jointly operated by DJB and Japan Real Estate Institute: <http://igb.jp/index.html> (in Japanese)